

Rolling Rails by the River

**IRON AND STEEL FABRICATION
IN SOUTH TRENTON**

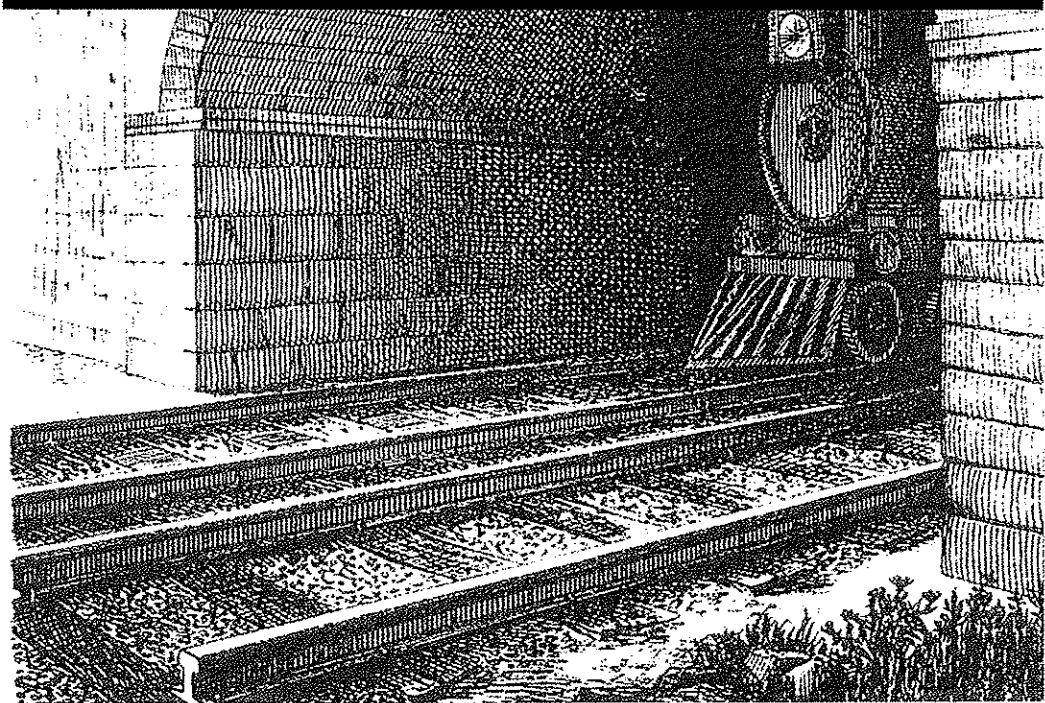

WORKSHOP OF AN INDUSTRIAL GIANT

Whence came those miles of iron rails that first laced America with railroads in the mid-19th century? Which factory turned out the structural I-beams for the first multistory buildings in our American cities? Where in the United States was steel first mass-produced using the open-hearth process?

The answer is the furnaces that once dominated the banks of the Delaware River at the foot of Federal Street in South Trenton. Successively home to the rolling mills of the Trenton Iron Company and the New Jersey Steel and Iron Company, then a key plant in the operations of the American Bridge Company and the U.S. Steel Corporation, this immense and enormously productive factory epitomized—as well as any other place in the city—the slogan “Trenton Makes, The World Takes.”

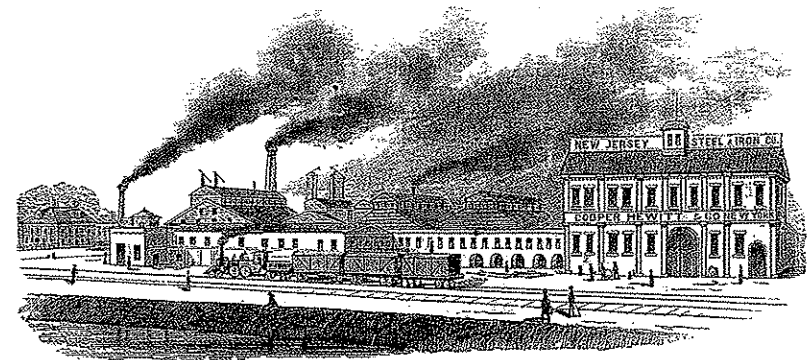

PETER COOPER'S IRON FOUNDRY AT TRENTON.

An illustration of the Trenton Rolling Mills in Frank Leslie's Popular Monthly, 1877. (Research Collections of Hunter Research, Inc.)

Few firms in the mid-19th century could match the Trenton Iron Company and the New Jersey Steel and Iron Company for their contributions to the nation's industrial development. There is no other industrial entity in the city—not even the Roebling company—that can lay claim to the range of achievement wrought by these two corporations founded and run by Peter and Edward Cooper and Abram and Charles Hewitt. This booklet tells the story of the Trenton Rolling Mills, one of a pair of Trenton Iron Company facilities established in the city that together formed the first major hub of the Cooper, Hewitt & Company's iron- and steel-making empire.

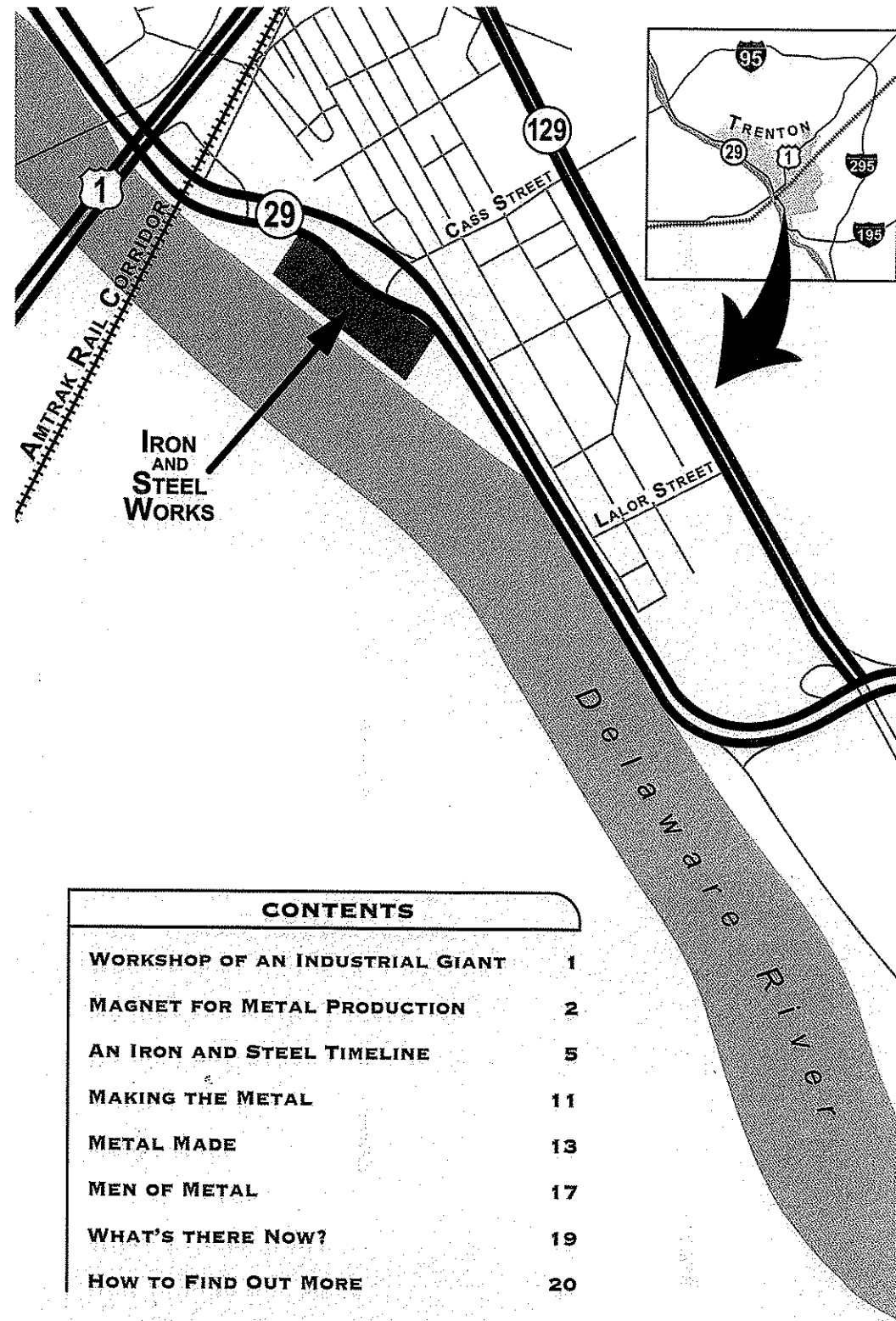

IRON AND STEEL WORKS

CONTENTS

WORKSHOP OF AN INDUSTRIAL GIANT	1
MAGNET FOR METAL PRODUCTION	2
AN IRON AND STEEL TIMELINE	5
MAKING THE METAL	11
METAL MADE	13
MEN OF METAL	17
WHAT'S THERE NOW?	19
HOW TO FIND OUT MORE	20

MAGNET FOR METAL PRODUCTION

Location, location, location. This was the mantra of American industrialists in the 19th century every bit as much as it is of 21st-century real estate agents. And Peter Cooper, industrial entrepreneur *par excellence*, recognized better than anyone the extraordinary advantages of the rapidly growing city of Trenton.

Trentonians had dabbled in small-scale iron and steel manufacture in the mid-18th century. By 1790 these facilities had closed, unable to compete with British metalworking businesses. They had been sustained by many of the advantages that later supported the city's rise to iron- and steel-making prominence: proximity to iron, wood, and charcoal; a ready supply of water power; and a well-developed regional transportation network.

By the mid-1840s, when Peter Cooper arrived on the scene, several changes had made Trenton ripe for industrial development. Improvements in mining and smelting technology increased the available supply of coal in northeastern Pennsylvania and iron in New Jersey. In Trenton the construction of a power canal in the early 1830s was

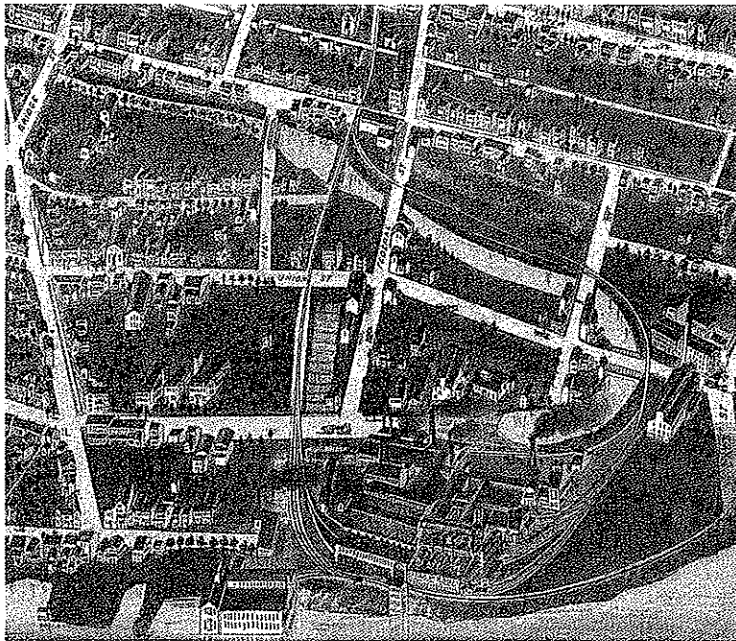

Part of Fowler & Bailey's bird's eye view of Trenton produced in 1874 showing the Trenton Rolling Mills at the downstream end of the Trenton Water Power. (Private Collection)

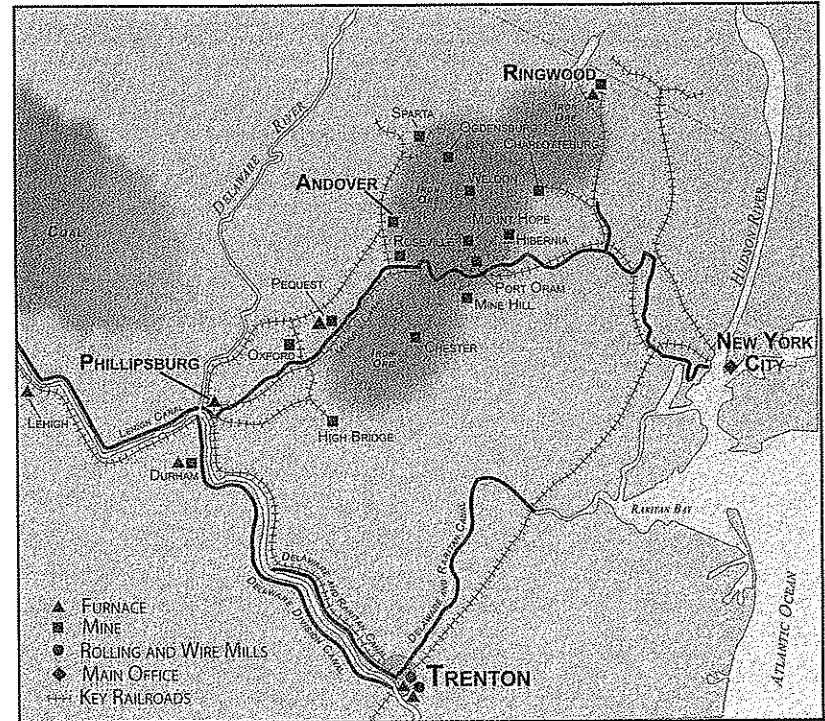

Trenton's position in the Cooper, Hewitt & Company mid-19th-century iron production network. (Hunter Research, Inc.)

attracting water-powered industrial development (see the companion booklet *Power to the City*). The city's resulting growth had swelled the labor pool for industrial jobs, and the expanding urban population along the eastern seaboard amplified the markets for iron and steel products.

Yet the real spur to Trenton's mid-19th-century industrial growth was the transportation revolution. Turnpikes, canals, and railroads linked the city to more distant raw materials and a much larger market area. More than any other single factor, it was these improvements in transportation that cemented Trenton's position as a manufacturing powerhouse.

From 1804 the creation of the Trenton and New Brunswick "Straight" Turnpike (today's Brunswick Avenue and Route 1) and the related construction of the first bridge over the Delaware River had a profound effect on Trenton's accessibility. The Delaware and Raritan Canal, built 1831–34, channeled raw materials and manufactured



Peter Cooper (1791-1883), industrialist, philanthropist, and founder of the Trenton Iron Company and the Trenton Water Power Company. [Courtesy of the Cooper Union for the Advancement of Science and Art]

goods into and out of the city, essentially along the same corridor. And then came the railroads. In 1839–40, the Camden & Amboy and Philadelphia & Trenton Railroads threaded rails through Trenton along the canal and turnpike routes, bringing more freight and passengers into the city and raising Trenton to a new plane of industrial opportunity. From this point on, for more than a century, raw materials, fuel, and manufactured products—all the life-blood of industry—coursed through these Trenton transportation arteries.

Peter Cooper likely passed through Trenton by rail often in the early 1840s. A resident of New York City, he maintained business and political contacts up

and down the east coast. As his vision of mass-produced iron and steel began to take shape, the geographical advantages of Trenton as a potential manufacturing hub became evident to him. Before the decade was over, Cooper, his son Edward, and son-in-law Abram Hewitt had assembled the basic blocks upon which the Cooper, Hewitt & Company enterprises were founded: iron mines in the Andover region of the New Jersey Highlands, where both hematite and magnetite ores could be extracted; blast furnaces in Phillipsburg on the Upper Delaware, where primary ore processing could be carried out using anthracite coal brought down the Lehigh Valley; and the rolling mills and wire mills of the Trenton Iron Company in Trenton, where iron was rolled, drawn, and slit into bars, beams, plates, rods, and other items used in the fabrication of locomotives, railroad infrastructure, steamships, bridges, and eventually, even buildings.

A web of canals and rails—the Morris, Lehigh, Delaware, and Delaware and Raritan canals; the Sussex, Morris & Essex and Belvidere Delaware railroads—linked this production triangle and focused ultimately on the manufacturing sites in Trenton. These and other rail and water routes tying Trenton to other eastern seaboard cities ensured that the iron and steel products were available to metal-working businesses and markets across the country.

AN IRON AND STEEL TIMELINE

ENTER THE TRENTON IRON COMPANY (1844–47)

It was in 1844 that Peter Cooper arrived in Trenton with his far-reaching plans to establish an ironworks on the banks of the Delaware River, putting an entirely new complexion on the industrial future of the city. Cooper immediately began working behind the scenes to acquire control of the seven-mile-long power canal built by the Trenton Delaware Falls Company (then in receivership) and purchase the necessary land in South Trenton for the new ironworks. On June 2, 1845, Cooper secured ownership of the two key lots in South Trenton where he planned to erect his rolling mills and a wire and rod mill. This property straddled a segment of the looping head race at the downstream end of the power canal, and contained within its limits the former Sartori residence known as Rosey Hill, soon to become an ironmaster's residence and company office (see the companion booklet *A Tale of Two Houses*).

By the fall of 1845, the mills were up and running, and the production of bars, rods, and wire began in earnest. Early in 1846 the factory began filling an order from the Camden & Amboy Railroad for 2,000 tons of Robert Stevens' patent T-rail. By the end of the year, the rolling mills were producing 40–50 tons of rails daily and had more orders than they could meet. Over the next few years the plant was greatly enlarged, with the wire mill operations being moved in 1849 to a new site on Sandtown Road (today's Hamilton Avenue) next to the Delaware and Raritan Canal and Camden & Amboy Railroad. Together, the rolling mills and wire mills employed close to 500 workers.

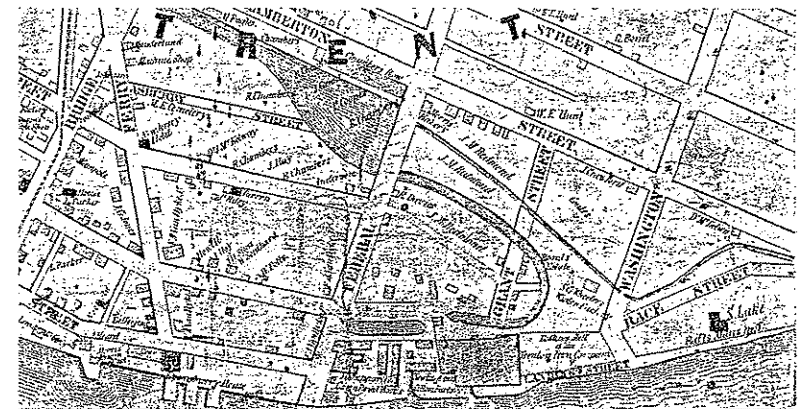

Part of Otley and Keily's map of Trenton, published in 1849, showing the Trenton Rolling Mills and other industrial facilities at the downstream end of the Trenton Water Power. [Trenton Public Library]

The rapid success of the Trenton factories required a strong corporate framework, which emerged in 1847. On February 16, "an Act to incorporate the Trenton Iron Company" was approved by the New Jersey legislature. The initial stock issue made on March 1, 1848, amounted to \$300,000, with Peter Cooper holding \$151,000 and a newly established firm "Cooper & Hewitt" holding \$149,000. This latter partnership linked Edward Cooper and Abram Hewitt in a management company that oversaw and coordinated the many aspects of the growing business from the mining of ore through the primary and secondary processing of the metal to the marketing and distribution of the final product.

TWO TITANS OF INDUSTRY

The Trenton Iron Company operated two sprawling factories in Trenton: the rolling mills on the banks of the Delaware, the subject of this booklet, which began operating in 1845; and the wire mills on Hamilton Avenue, opened in 1849, whose production of iron rod and cable was closely allied with the wire rope business of John A. Roebling and the burgeoning demand for telegraph wire and wire fencing. The two Trenton Iron Company plants were linked by rail and operated in close concert, with the rolling mills feeding bars and plates to the wire mills for further fabrication. During the Civil War the two plants combined to produce gunmetal, gun barrels, and other ordnance.

ON A ROLL (1847-57)

By any measure, the Trenton Iron Company grew rapidly from the late 1840s into the mid-1850s. The company continued to acquire land in the area below Federal Street to allow for expansion, taking up undeveloped mill sites to the south of Grant (Lexington) Street and also purchasing the mill lots of the defunct New England Manufacturing Company and the fire-damaged Union Print Works. Some purchases were also related to a long-awaited rail link that finally arrived in 1853, while others were intended to support new industrial facilities and workers' housing.

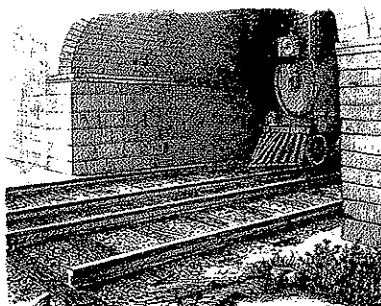

Railroads—the first major customers of the Trenton Iron Company.
[Benjamin Butterworth, *The Growth of Industrial Art*, 1892]

In 1850 the rolling mills had 16 furnaces and were using both steam and water power. The company was still focusing its production on the manufacture of iron rails, and counted among its clients many of the largest and best-known railroad companies east of the Mississippi. However, in response to strong British competition, the Trenton Iron Company was also developing other avenues of iron and steel manufacture on two fronts: stepping up the production of wire; and rolling better quality wrought iron beams for structural use in buildings and bridges, in addition to rails.

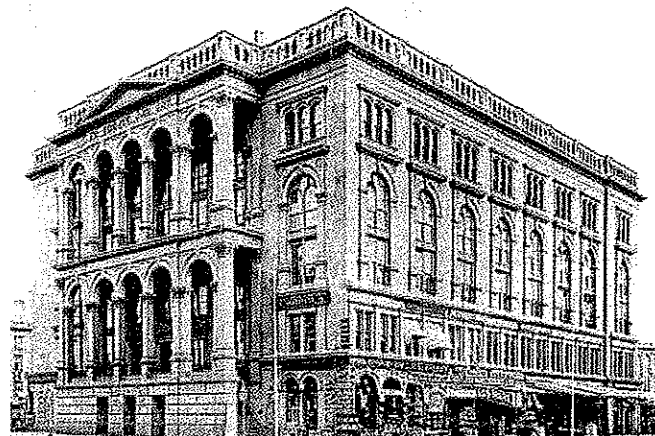

A view around 1860 of the Cooper Union building, constructed with wrought-iron I-beams made at the Trenton Rolling Mills.
[Ringwood State Park, New Jersey Division of Parks and Forestry]

The company's shift toward producing structural iron in building construction began in 1852, just as the price of rails was rising in response to a worldwide surge in railroad building. By 1854 the Trenton Iron Company was producing seven-inch-deep wrought iron beams with rounded top edges and a profile similar to that of an iron rail. These first products, known as "bulb-tees," were used as floor joists for various buildings in New York City, including the Cooper Union building in Cooper Square. By 1856 the company was rolling nine-inch-deep I-beams, the first true I-beam manufactured in the United States. Within a year the firm was conducting extensive business with railroad companies and with the federal government. Iron rails were still being made for several railroads, but beams and girders were also being shipped out across the country in large quantities for government construction projects, including nine Custom Houses, the U.S. Capitol Extension, the U.S. Patent Office, the Branch Mint in New Orleans, Fort Sumter, and two marine hospitals.

DEPRESSION AND WAR (1857-66)

After the rapid expansion and immediate profitability of the Trenton Iron Company in the mid-1850s, international competition caused the price of rolled iron to fall dramatically during 1856. A full-fledged financial panic struck American manufacturing in 1857, and with banks calling in loans, the Trenton Iron Company, short of cash, began laying off workers. Production at the rolling mills ground to a virtual halt, despite several unfilled orders. The company eventually weathered the storm by resorting to various cost-cutting measures, such as reducing the inventory of iron bar stock and paying workers with goods from the company stores.



*During and after the Civil War the Trenton Iron Company mass-produced gunmetal for firearms and artillery used by the Union Army. [Benjamin Butterworth, *The Growth of Industrial Art*, 1892]*

By the spring of 1858 the iron business began to pick up again. The Trenton Iron Company survived with its capital intact and no major debts. Production soon returned to its pre-1857 levels, and the company resumed its main business of manufacturing iron rails and structural beams and girders. By 1860 there were no less than 27 furnaces in operation at the rolling mills.

With the outbreak of the Civil War in 1861, the firm lost most of its southern clients. By the end of the year, the Trenton Iron

Company's mills in Trenton had retooled and were equipped with new machinery that could produce 1,000 gun barrels a week. The rolling mills at first had difficulty making good-quality gunmetal, requiring Abram Hewitt to travel overseas and observe English manufacturing processes. By late 1862 the Trenton Iron Company was a major supplier of gunmetal to the Springfield and Watertown armories and of gun barrels to several private gun manufacturers.

NEW JERSEY STEEL AND IRON...

...AMERICAN BRIDGE (1866-1976)

After the Civil War, a sluggish economy set in, causing a re-organization of the Trenton-based operations of the Cooper, Hewitt & Company empire. From this emerged, in 1866, the New Jersey Steel and Iron Company. The new entity took over the rolling mills and the

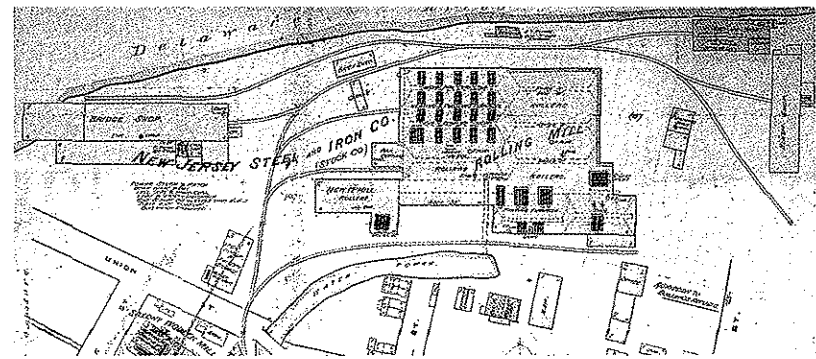

A Sanborn fire insurance map of 1874 (updated to 1886) depicts the rolling mill complex of the New Jersey Steel and Iron Company. [Trenton Public Library]

Trenton Water Power, while a reconfigured Trenton Iron Company continued to control the wire mill complex on Hamilton Avenue, the Andover iron mines, the Phillipsburg furnaces, and the mines and iron-works in the Ringwood area of Passaic County, New Jersey.

As its name implies, the New Jersey Steel and Iron Company emphasized production of steel rather than iron, and the new corporation was soon making steel on the old rolling mill site using the new Siemens-Martin open-hearth process. The main product, a combination iron and steel rail, was commercially doomed, however, as the Trenton steelworkers could not maintain adequate temperature control in the furnace. By 1872 rails made by the open-hearth process had been replaced throughout the industry by all-steel rails made using the Bessemer process, a production method never adopted in Trenton by the New Jersey Steel and Iron Company.

Over the course of the 1870s, the New Jersey Steel and Iron Company withdrew from the manufacture of rails, ceding this business to other companies in western Pennsylvania and beyond. Instead, the firm turned its attention to producing steel beams, girders, plates, and chains for use in the fabrication of bridges and ships, as well as some more specialized



Fowler's bird's eye view of Trenton in 1893 shows the sprawling works of the New Jersey Steel and Iron Company on the banks of the Delaware. [Courtesy of the New Jersey State Library]

items such as ships' anchors. By 1880 rail production had ceased altogether and the company operated two facilities: an anchor and chain shop producing goods valued at \$60,000; and a bridge shop producing bridge parts valued at close to \$400,000. The shift in production emphasis in the 1870s was accompanied by extensive rebuilding at the plant and by the abandonment of water power in favor of coal-fired steam. The one surviving building on the site today, a machine shop now remodeled as a restaurant, dates from this period.

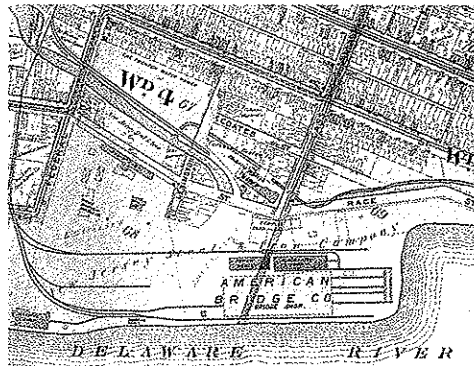

Lathrop's Atlas of the City of Trenton published in 1905 shows the works of the American Bridge Company. [Research Collections of Hunter Research, Inc.]

The New Jersey Steel and Iron Company was sold in 1900 to the newly incorporated American Bridge Company. In the following year the American Bridge Company was itself purchased by the United States Steel Corporation. The mills at Trenton were recast as a series of machine shops engaged mostly in the fabrication and assembly of bridge components. By 1905 the bridge shop had been expanded, and the rolling mills and several other buildings demolished. Template and cutting shops were soon added, and several crane ways were erected.



An aerial view of the American Bridge Company works in 1928.
[Trenton Public Library]

The site effectively functioned as a sort of life-size erector set. Despite dips in production and the loss of part of the site to highway construction (John Fitch Way, the predecessor to Route 29) in the 1930s, the American Bridge Company's South Trenton plant stayed in operation until 1976, when U.S. Steel closed the site during a period of nationwide downsizing in the steel industry.

MAKING THE METAL

Making iron and steel entails mining iron ore, smelting the ore to separate the metal, reheating and reworking the metal into intermediate forms such as bars, plates, and rods, and then fabricating these materials into finished objects such as rails, beams, nails, or locomotive parts. Several stages and places of manufacture may be involved before ore is converted into marketable metal product.

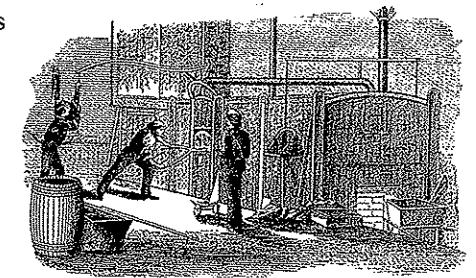

Molten iron being extracted from a puddling furnace. [Knight's American Mechanical Dictionary, 1876]

The path of raw material to the Trenton Iron Company's mills in Trenton began in the New Jersey highlands. There the iron ore was mined and transported to blast furnaces in Phillipsburg, where it was smelted using anthracite fuel from the Lehigh Valley. Pig iron cast in the Phillipsburg furnaces was then shipped to Trenton by rail, where it was reheated and balled in puddling furnaces, and then passed through rollers that shaped it into bars or sheets. Trip-hammers and cutting machinery completed the manufacturing processes and the iron left the

IRON LINGO I

Pig iron is "iron in pigs, or oblong blocks or bars, as it comes from the smelting furnace in the form of cast-iron run into molds of sand." Wrought iron is "the purest form of iron known in the arts. It is soft, very tenacious, and at a high temperature may be welded. It possesses great malleability and ductility. When beaten into bars, it is known as bar iron or merchant-bars." Steel is "iron combined with a small portion of carbon." Puddled steel, as made at the Trenton Rolling Mills, is "steel made from cast iron (pigs) by a modification of the puddling process." [All definitions from Webster's Dictionary, 1847.]

plant either in finished form, such as rails, or semi-processed to the point where it could be fashioned further in other metalworking establishments, as was the case, for example, with gunmetal. The various types of product emanating from the Trenton Iron Company's rolling mills were referred to generically as wrought iron (as opposed to cast iron, which was typically formed by pouring molten metal into molds).

Anthracite coal fueled the puddling furnaces in the rolling mills, while water power initially drove the key mechanical processes of hammering, rolling, and cutting. Water power also supplied the energy for operating the bellows and tuyeres, which regulated the furnace heat. However, within a decade, the power needs of the rolling mills exceeded the capacity of the Trenton Water Power Company, and coal-fired steam power began to take its place. By 1870 the factory housed two waterwheels generating 100 horsepower and 10 steam engines generating 400 horsepower. Water power was phased out altogether by the end of the 1880s.

The technology of the puddling furnace changed little during the period of the rolling mills' operation, but Abram and Charles Hewitt strove continually to improve the quality of the wrought iron being produced,

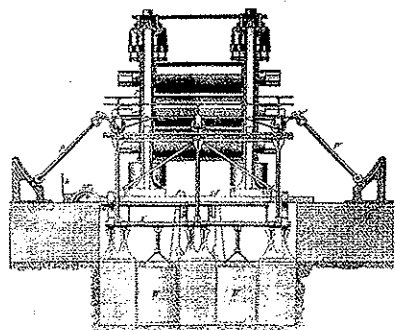

The three-high beam rolling mill developed by Charles Hewitt at the Trenton Rolling Mills. [Courtesy of Hagley Museum and Library]

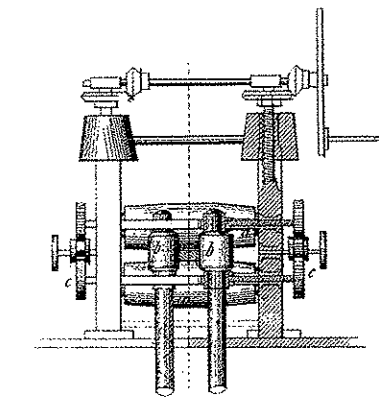

A universal rolling mill with horizontal and vertical power-driven rolls. [Bruno Kerl, *Handbuch der Metallurgischen Huttenkunde*, 1855].

the design of the rolling machinery, and the overall efficiency of the plant. In the early 1850s Charles Hewitt, using designs created by a foreman at the Trenton plant named William Borrow, developed a heavy-duty universal mill that could roll out both structural beams and heavy rails. This equipment soon became the industry standard. Charles Hewitt also designed a machine to mass-produce rail

"chairs" (the iron sockets that fastened to the ties and held the rails in an upright position) and made countless other improvements to machinery used in making wrought iron.

The Hewitts had followed British and American advances in steel-making with intense interest. Steel, a stronger and harder metal than iron, was difficult to produce, requiring careful control over temperature and carbon content. In the late 1860s the New Jersey Steel and Iron Company mass-produced the first steel rails and beams in America at the Trenton mills using the open-hearth process. Steel made in this fashion, termed mild or puddled steel, remained the mills' staple until the end of the century.

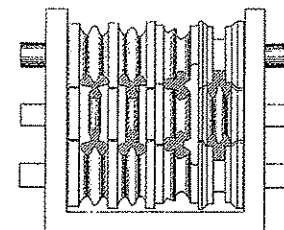

Three-high rolls for making triple-headed rails. [Knight's *American Mechanical Dictionary*, 1876]

IRON LINGO II

"In the rolling mill, the iron, which is heated and balled in the puddling furnace, is made into bars or sheets." A puddling furnace is "one in which pig iron ... is melted and continuously stirred for a considerable time while boiling ..." [Knight's *American Mechanical Dictionary*, 1876].

METAL MADE

Aside from gunmetal production during the Civil War, rails and beams dominated the output of the rolling mills at the foot of Federal Street. Beginning with the distinctive flanged T-rail made for the Stevens family's Camden & Amboy Railroad in the late 1840s, increasing quantities of steadily improved wrought-iron rails poured forth, culminating in the steel-topped rail that was first manufactured in 1866. By 1870 the mills had the capacity to produce an astounding 24,000 tons of rail a year. Over a quarter century, Cooper, Hewitt & Company built up an impressive client list for their rail product that included major railroad companies like the Illinois Central, the Erie, and the Pennsylvania.

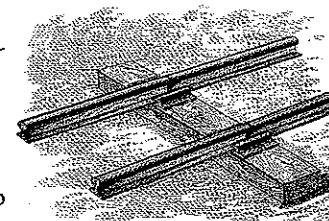

Rails—a staple product of the Trenton Rolling Mills for a quarter century from the late 1840s. [Benjamin Butterworth, *The Growth of Industrial Art*, 1892]

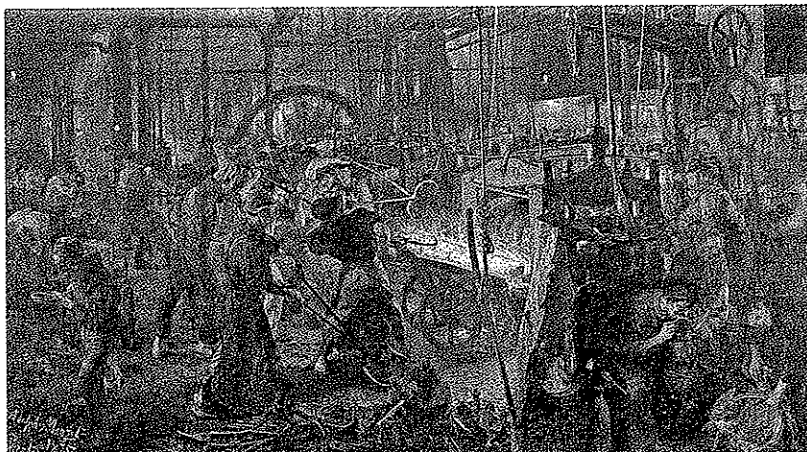

Adolph Menzel's *The Iron Rolling Mill*, painted in 1875, captures vividly the hot and strenuous business of making iron. [Bildarchiv Preussischer Kulturbesitz / Art Resource, NY]

Following a parallel and closely related track was the Trenton Iron Company's development of wrought-iron structural beams. By 1853 the rolling mills were successfully turning out flanged beams 7 inches deep in cross section and up to 25 feet in length. Out of this product emerged the I-beam, one of the greatest American contributions to the Industrial Revolution, and an achievement that profoundly transformed architectural design and civil engineering into the modern age. Largely fireproof, rigid, and able to distribute considerable loads from multiple upper floors to foundations, the I-beam has served as the skeletal material for multistory construction the world over for some 15 decades and counting. This mode of construction traces back directly to the Cooper Union edifice, erected 1854–58, and a multitude of public buildings built in the pre-Civil War era.

With the onset of the Civil War in 1861, production shifted from wrought-iron rails and beams to materials that filled the Union Army's needs. The Trenton Iron Company churned out vast quantities of high-quality gunmetal; as much as 10 tons daily in 1863. A single order from the U.S. Ordnance Bureau in late 1863 requested 5,000 long tons of gunmetal,

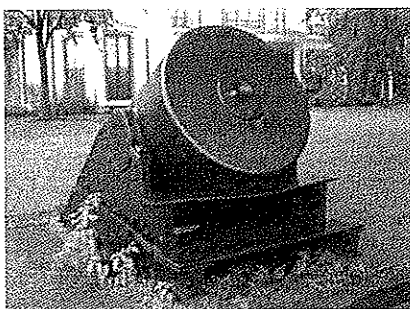

The beds for many Civil War-era mortars were made by the Trenton Iron Company's Trenton facilities. [Ringwood State Park, New Jersey Division of Parks and Forestry]

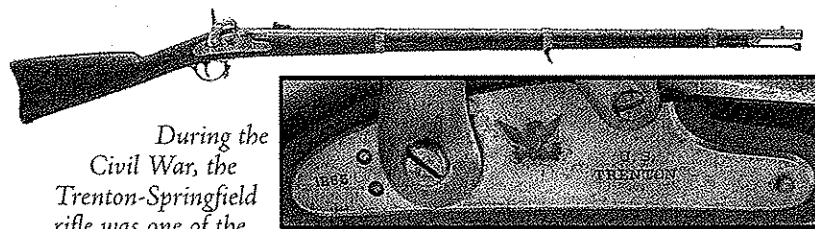

During the Civil War, the Trenton-Springfield rifle was one of the Trenton Iron Company's trademark contributions to the Union Army's repertoire of firearms. [Collectors Firearms, Houston, Texas]

enough iron for a million rifles and muskets. The Trenton-Springfield rifle, a standard weapon of the time, was assembled *en masse* at the Springfield Armory using gunmetal produced in Trenton. The Trenton Iron Company further provided the Army with rails, wire, pig iron, artillery carriages, gun-sockets, and entrenching tools, and was a major supplier of gun barrels to gun manufacturers working under contracts to the government.

After the war and the creation of the New Jersey Steel and Iron Company, the Trenton Rolling Mills concentrated again on making rails and beams, increasingly in steel. The finished product was shipped out of the plant by rail on the Camden & Amboy/Pennsylvania network or down the Delaware by steamboat from the company wharf at the foot of Federal Street. Sales and marketing were handled through the Cooper, Hewitt & Company offices at 17 Burling Slip in Manhattan. During the 1870s the factory ceased the production of rails and focused instead on making beams and girders for bridges, also developing a sideline in ships' anchors and chains. From the turn of the century, as one of a consortium of American Bridge Company plants, the site produced steel for bridges

One of many types of steel I-beam being marketed by the New Jersey Steel and Iron Company in 1874.

[Courtesy of Hagley Museum and Library]

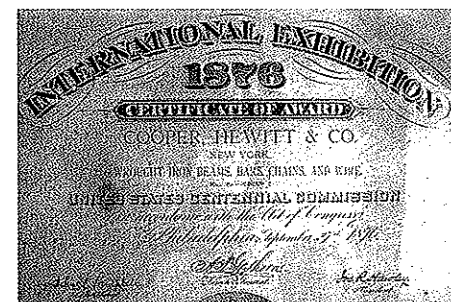
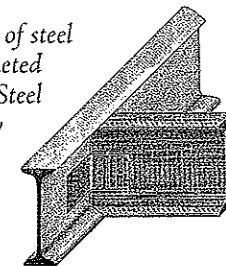

Trenton-made ironwork won Cooper, Hewitt & Co. an award at the Centennial Exhibition in Philadelphia in 1876. [Ringwood State Park, New Jersey Division of Parks and Forestry]

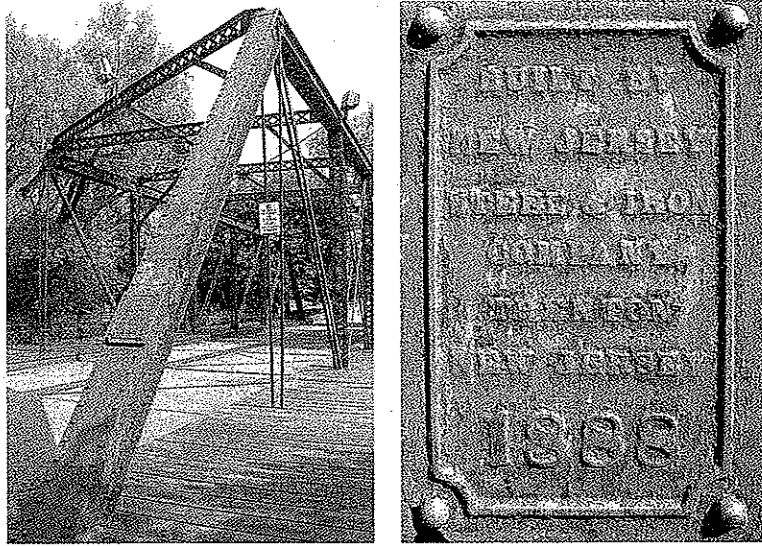

The Jackson Street bridge in Trenton's Mill Hill Park, one of many metal truss bridges fabricated by the New Jersey Steel and Iron Company in the late 19th century. [Hunter Research, Inc.]

and buildings. In this final 75-year-long phase of its history, the factory provided structural steel components for many well-known architectural and engineering landmarks, including the Chrysler Building, the General Motors Building, Rockefeller Center, the United Nations Complex, and the Verrazano Narrows Bridge (all in New York City), the Tappan Zee Bridge over the Hudson River, and the Delaware Memorial, Walt Whitman, and Tacony-Palmyra Bridges (all spanning the Delaware River). Steel from the Trenton plant went far beyond the United States. In 1914, for example, 4,960 tons of steel were delivered to Panama for use in the erection of 824 power transmission towers along the railroad corridor adjoining the Panama Canal.



Built in 1928–29, the Tacony-Palmyra bridge over the Delaware River was one of many spans for which the American Bridge Company supplied structural steel. [Hunter Research, Inc.]

When it comes to the Industrial Revolution, history shines its spotlight mostly on the entrepreneurs and investors, the inventors and innovators. The Trenton Rolling Mills can offer up its fair share of such individuals—Peter Cooper, Edward Cooper, Abram S. Hewitt, Charles Hewitt (each here the subject of a vignette); and then an array of other prominent figures—investors like Robert J. Walker, a former Secretary of the Treasury, Edwin Post, another New Jersey ironmaster, and Edwin A. Stevens of the engineering dynasty of Hoboken; and longtime officers of both the Trenton Iron Company and the New Jersey Steel and Iron Company like Timothy Abbott and James Hall.

Early in his career, **Peter Cooper** (1791–1883) excelled as an inventor and mechanic, designing and operating one of America's first locomotives, the *Tom Thumb*. His business fortune was initially founded on glue-making, but his true interest lay in ironmaking. He constructed an ironworks in New York City in the 1830s, and then in the mid-1840s set up a vastly expanded operation anchored by the Trenton Iron Company and Cooper, Hewitt & Company. From the mid-1850s, Cooper was also a leader in the telegraph cable business, another source of his considerable wealth. In his later years he turned his attention to philanthropy and politics, founding the Cooper Union and running unsuccessfully in 1876 as the Presidential candidate for the Greenback Party. **Edward Cooper** (1824–1905), a principal of both the Trenton Iron Company and Cooper, Hewitt & Company, played a leading role in establishing and operating the Trenton Rolling Mills from the late 1840s through the Civil War era. He served one term as Mayor of New York City in 1879–80.

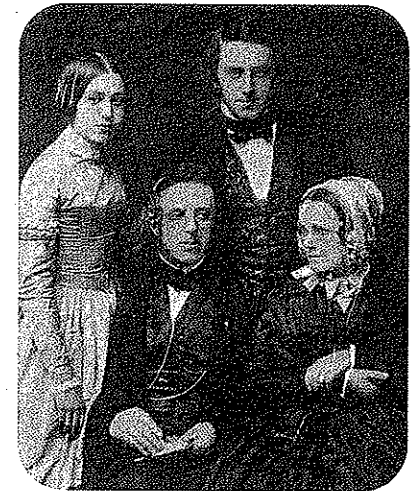

The Cooper family in the early 1840s—Peter Cooper and his wife, Sarah Bedell Cooper (seated at front) with two of their children, Edward Cooper and Amelia Cooper, future wife of Abram S. Hewitt. [Allan Nevins, *Abram S. Hewitt with Some Account of Peter Cooper*, 1935]



Abram S. Hewitt
[Allan Nevins, *Abram S. Hewitt with Some Account of Peter Cooper*, 1935]

Abram Hewitt (1822–1903), a stellar student at Columbia College, trained as a lawyer, but soon became involved in the affairs of Peter Cooper as a tutor and friend to his son, Edward. Hewitt went on to marry Edward’s sister, Amelia. An astute businessman with a strong interest in iron and steel manufacturing processes, he was a driving force behind the rise of the Cooper, Hewitt & Company empire. Politically well-connected, he went on to serve as a U.S. Representative for five terms beginning in 1874 and as Mayor of New York City in 1887–88.



Charles Hewitt
[E.M. Woodward and John F. Hageman, *History of Burlington and Mercer Counties*, 1883]

Charles Hewitt (1824–79), the younger brother of Abram S. Hewitt, managed the Trenton Iron Company’s Trenton operations for many years, living in the Rosey Hill mansion at the rolling mills site. An accomplished engineer and mathematician, he made several important innovations in the design of iron and steel making furnaces and rolling machinery.

But what of the mill workers, the countless toiling company employees who endured the searing furnace heat, the deafening noise of hammers and rollers, the lung-reducing smoke, and the backbreaking weight of iron and steel and coal? These individuals are less easily brought on to the pages of history and the physical toll taken on their lives is hard to imagine. The size of the labor force at the rolling mills is difficult to pin down, but probably totaled close to 500 in the plant’s heyday in the third quarter of the 19th century.

A mix of skilled, semi-skilled, and unskilled workers—machinists, blacksmiths, puddlers, heaters, rollers, ironworkers, helpers, and laborers—toiled at the site. Their names can be extracted from the census and city directories: names like Robert Lawson and Moses Lozell, both residents of Federal Street, two out of 49 puddlers; Jerod Hoyt of South Warren Street, one of 14 heaters; or William Keough of Union Street, one of a dozen rollers—all listed in a directory of 1859. There is

a high incidence of Irish, English, and German surnames linked to these occupations, and many of the workers lived in the surrounding streets of Lambertson and South Trenton, giving rise to blocks of distinctively named row housing like Puddlers Row and Helpers Row.

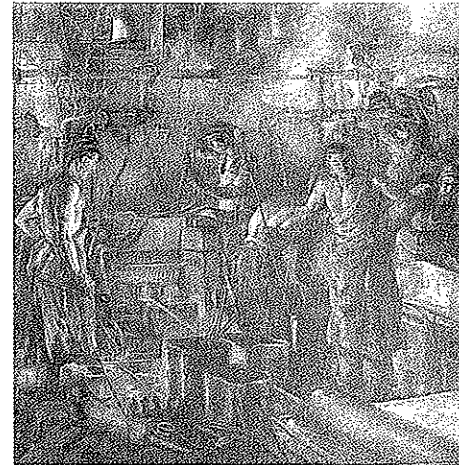

A panel depicting ironworking in progress included in the series of murals completed in 1911 in the Council Chambers of Trenton City Hall by artist, playwright, and actor Everett Shinn (1876–1953).
[City Hall, City of Trenton]

WHAT’S THERE NOW?

Today, a single historic industrial building stands on the site of the Trenton Rolling Mills, operating as a restaurant and nightclub. This I-beam framed, brick-built structure, originally a machine shop erected by the New Jersey Steel and Iron Company in the early 1870s, still retains its vast cathedral-like central space, once equipped with gantries where bridge parts were crafted and assembled. However, in place of the clanks and thuds of industrial production that emanated from its walls more than a century ago, the waters of the Delaware River now deliver the thump of nighttime dance music to the riverside residential communities. The manufacture of entertainment has replaced the manufacture of metal.

There is scant trace today of the extraordinary industrial endeavor that pulsed here from the mid-19th century through the post-World War II era. A riverside battery of glass and steel office buildings, a baseball stadium, a parking deck, all connected by asphalt and concrete, now seal the footprints of one of the nation’s true industrial giants. Sadly, there is little at this site that acknowledges the mighty manufacturing contributions of the rolling mills of the Trenton Iron Company and the New Jersey Steel and Iron Company, a place where the fabric of railroads, skyscrapers, bridges, and weapons of war was so expertly fashioned at the peak of the American Industrial Revolution.

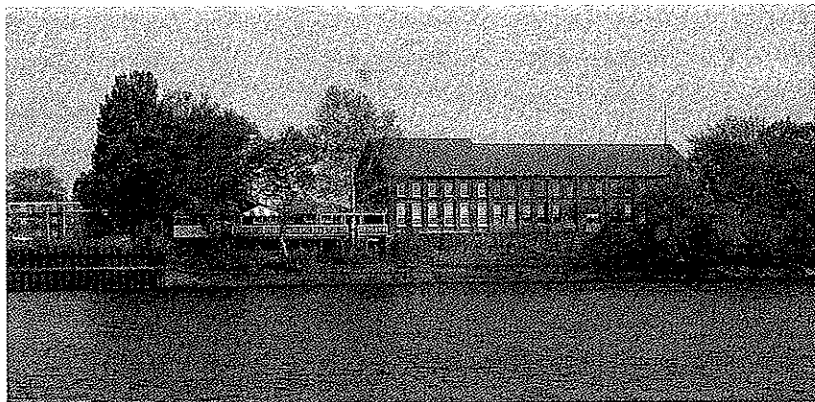

A modern view of the New Jersey Steel and Iron Company machine shop, built in the early 1870s, now adapted into a restaurant. [Hunter Research, Inc.]

HOW TO FIND OUT MORE

Places To Visit

- **New Jersey Steel and Iron Company Machine Shop**, Route 29, Trenton, New Jersey: a machine shop from the early 1870s, the only surviving building at the rolling mills site, retains much of its original fabric; a similar period Trenton Iron Company wire mill also stands on Hamilton Avenue.
- **Ringwood State Park and Long Pond Ironworks State Park**, Passaic County, New Jersey: Ringwood Manor, home of the Hewitt family, and the Long Pond Ironworks, a historic district with buildings and archaeological remains of an 18th- and 19th-century iron-making community, have strong links to the Trenton Rolling Mills.
- **Cooper Union**, Cooper Square, New York City: the Cooper Union for the Advancement of Science and Art, the main philanthropic legacy of Peter Cooper, is a private college specializing in art, architecture, and engineering; the mid-19th-century building, with its seminal I-beams, contains a library with a wealth of Cooper & Hewitt archives.

Reading Suggestions

Allan Nevins, *Abram S. Hewitt: With Some Account of Peter Cooper*, Harper & Brothers, New York, New York [1935].

Robert B. Gordon, *American Iron 1607-1900*, Johns Hopkins University Press, Baltimore, Maryland [1996].

CREDITS

This booklet series is the product of historical and archaeological investigations undertaken for the New Jersey Department of Transportation and the Federal Highway Administration in mitigation of the effects of the reconstruction of Route 29 in the City of Trenton. The preparation of these booklets and other related research activities were conducted in compliance with Federal and State historic preservation laws and regulations. For more detailed technical reporting of the topics addressed in these booklets, readers are referred to the five-volume *Archaeological Data Recovery Excavations and Monitoring, New Jersey Route 29, City of Trenton, Mercer County, New Jersey*, available at selected local libraries, the New Jersey Historic Preservation Office, and the New Jersey Department of Transportation.

This booklet was conceived and authored by Richard Hunter of Hunter Research, Inc. Janice Wilson Stridick of Wilson Creative provided design and editorial services.

We gratefully acknowledge: David Zmoda, Nicholas Caiazza, Robert Davies, and Kathy Diringier of the New Jersey Department of Transportation (project administration); Damon Tvaryanas, Nadine Sergejeff, James Cox, Richard Hunter, Ian Burrow, Patricia Madrigal, William Liebeknecht, Charles Ashton, and Rebecca White (research assistance) and Michael Murphy, James Lee, Frank Dunsmore, Douglas Scott, and Dawn Turner (graphics assistance) of Hunter Research, Inc.; Lisa Smith (graphic design) of Wilson Creative; Wendy Nardi of the Trentoniana Local History and Genealogy, Trenton Public Library; Sally Lane, Trenton Convention and Visitors Bureau; and Brian Morrell, Greater Newark Conservancy.

OTHER TITLES IN THE HISTORY TRACED BY ROUTE 29 BOOKLET SERIES

- **Ancient Ways: Native Americans in South Trenton, 10,000 B.C. to A.D. 1700**
- **A Tale of Two Houses: The Lambert/Douglas House and the Rosey Hill Mansion, 1700-1850**
- **Fish and Ships: Lambertton, the Port of Trenton**
- **Power to the City: The Trenton Water Power**
- **Quakers, Warriors, and Capitalists: Riverview Cemetery and Trenton's Dead**

Back Cover (bottom): *New Jersey Steel and Iron Company, circa 1880*. [Allan Nevins, *Abram S. Hewitt with Some Account of Peter Cooper*, 1935]

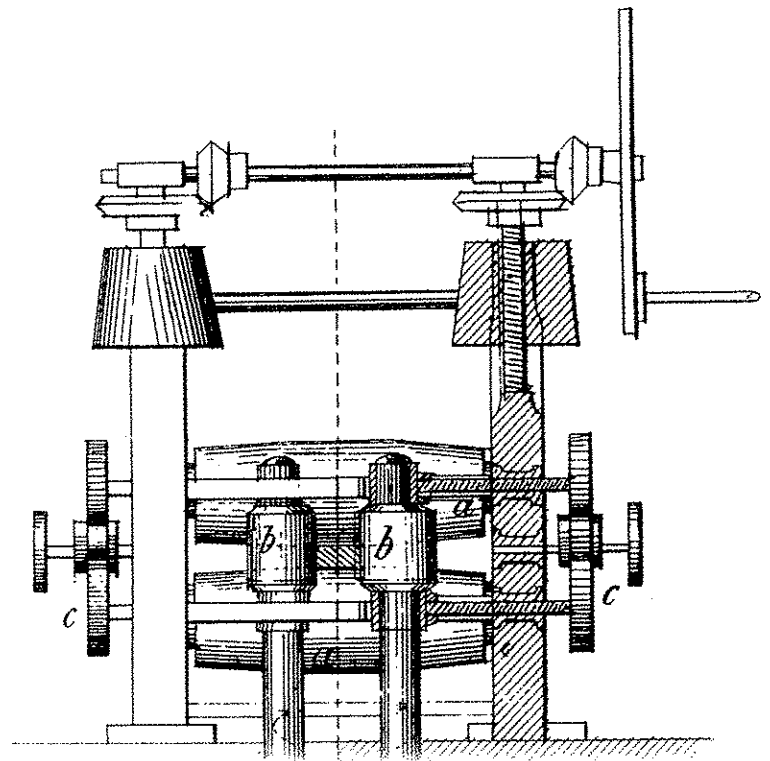

MADE POSSIBLE BY

 THE NEW JERSEY
DEPARTMENT OF
TRANSPORTATION

 U.S. DEPARTMENT OF TRANSPORTATION
FEDERAL HIGHWAY
ADMINISTRATION

